



**OPERATION AND MAINTENANCE MANUAL**

**DOCUMENT TITLE:** Operation and Maintenance Manual Ø55 API 17H 3rd edition  
Type 4 Hot Stab Program  
**PROJECT TITLE:** 600104 - Ø55 Hot Stab System  
**PROJECT:** 600104  
**PACKAGE DESCRIPTION:** Ø55 API 17H 3<sup>rd</sup> edition Type 4 Hot Stab Program  
**DOCUMENT NUMBER:** 600104-TD-0003  
**REV:** 03  
**NUMBER OF PAGES:** 17  
**DATE:** 08.10.2019



## OBJECTIVE

The objective of this document is to present an Operation and Maintenance Manual for the Ø55 Hot Stab Program delivered by Blue Logic AS. All relevant aspects with regards to safe and correct use, installation, operation, maintenance and storage are covered.

## ABSTRACT

The Blue Logic Ø55 Type 4 Hot Stab program is a High Flow Hot Stab system designed according to API 17H 3<sup>rd</sup> edition Type 4, for operation by use of ROV. The system consists of Male Hot Stabs, Receptacles and related equipment and components.

For full program overview and further technical details, please visit:

<http://e-sea.bluelogic.no/main.aspx>

## REVISION CHANGE/RECORD

REV	REASON FOR REVISION/ DESCRIPTION OF CHANGES
01	Document initiated, Prepared and Issued as general information
02	Added Lock Mechanism information
03	Update according to API 17H 3 <sup>rd</sup> edition



**TABLE OF CONTENT**

- 1. INTRODUCTION ..... 4**
  - 1.1. DOCUMENT USE..... 4
  - 1.2. REFERENCES..... 4
  - 1.3. ABBREVIATIONS..... 4
  
- 2. TECHNICAL DESCRIPTION..... 5**
  - 2.1. DESIGN AND TEST ..... 5
  - 2.2. TECHNICAL PERFORMANCE..... 5
  - 2.3. PROGRAM OVERVIEW ..... 5
  - 2.4. HOT STAB..... 6
    - 2.4.1. Hydraulic Ports ..... 6
  - 2.5. RECEPTACLE ..... 7
  - 2.6. PROTECTION STAB..... 7
  - 2.7. PRESSURE STAB..... 8
  - 2.8. LOCKING MECHANISM..... 8
  
- 3. INSTALLATION.....10**
  - 3.1. RECEPTACLE ..... 10
    - 3.1.1. Installation of Receptacle..... 10
  
- 4. OPERATION ..... 11**
  - 4.1. PRE-DIVE CHECK.....11
    - 4.1.1. Stab .....11
    - 4.1.2. Receptacle.....11
  - 4.2. CONNECTION.....11
  - 4.3. DISCONNECTION.....12
  - 4.4. POST DIVE CHECK .....12
  
- 5. MAINTENANCE .....13**
  - 5.1. SEAL REPLACEMENT.....13
    - 5.1.1. Removal of Seal .....13
    - 5.1.2. Installation of new Seal.....13
    - 5.1.3. Installation of new Seal Using Seal Replacement Tool.....14
  - 5.2. ROV INTERFACE..... 16
  - 5.3. FLEX JOINT ..... 16
  - 5.4. SPARE PARTS..... 16
  
- 6. STORAGE AND TRANSPORT..... 17**
  - 6.1. PRESERVATION FOR STORAGE.....17
  - 6.2. TRANSPORT .....17

## 1. INTRODUCTION

The Blue Logic Ø55mm Hot Stab Program is a very compact and light weight pressure balanced high-flow fluid connector system designed for ROV use where high flow and easy connection is required. The system design is based on API 17H 3<sup>rd</sup> edition Type 4

For a complete program overview, please visit: <http://e-sea.bluelogic.no/main.aspx>

### 1.1. DOCUMENT USE

This document shall be used as a guideline and reference document with regards to installation, operation and storage of the Ø55 Hot Stab System.

### 1.2. REFERENCES

<http://e-sea.bluelogic.no/main.aspx>

### 1.3. ABBREVIATIONS

ROV:	Remotely Operated Vehicle
HPU:	Hydraulic Power Unit
FAT:	Factory Acceptance Test

## 2. TECHNICAL DESCRIPTION

### 2.1. DESIGN AND TEST

The Blue Logic Hot Stab program are calculated, designed, tested and documented in accordance with API6A (ISO10423) and API 17H with regards to calculations, material usage and pressure test. All Hot Stab equipment is pressure tested to 1.5 x Design Pressure accordingly.

### 2.2. TECHNICAL PERFORMANCE

The Blue Logic Ø55 Hot Stabs are Based on API 17H 3<sup>rd</sup> edition Type 4. They can be delivered in different types and configuration. Hot Stabs for Permanent use, ROV use, and different pressure ratings. What is important to consider when selecting a Hot Stab is the flow capacity. As the flow increase you will experience pressure loss over the connection. This means that you will have less pressure available to do the hydraulic job.

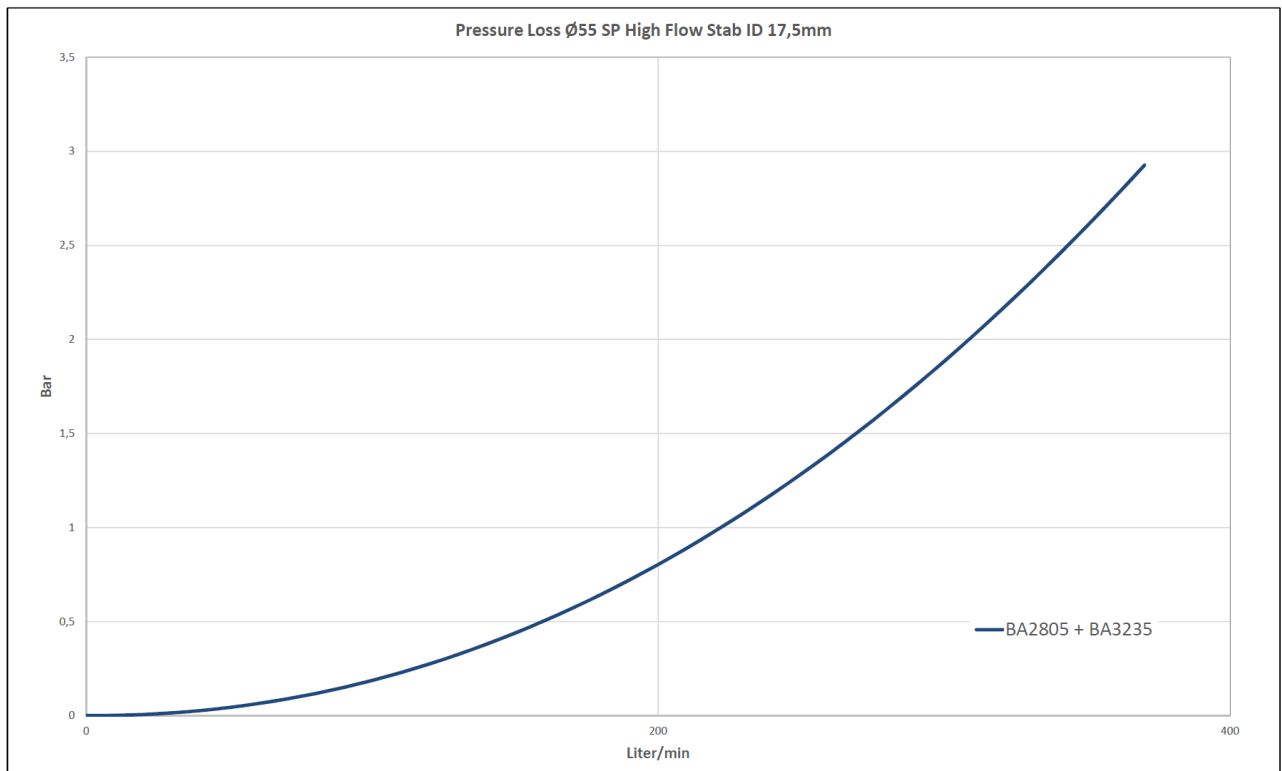

Figure 1 Typical Pressure vs Flow diagram Ø55 Hot Stab

### 2.3. PROGRAM OVERVIEW

The Ø55 Hot Stab Program can be delivered with alternative ROV Handles, seals and hydraulic interfaces. Contact Blue Logic for further information

2.4. HOT STAB

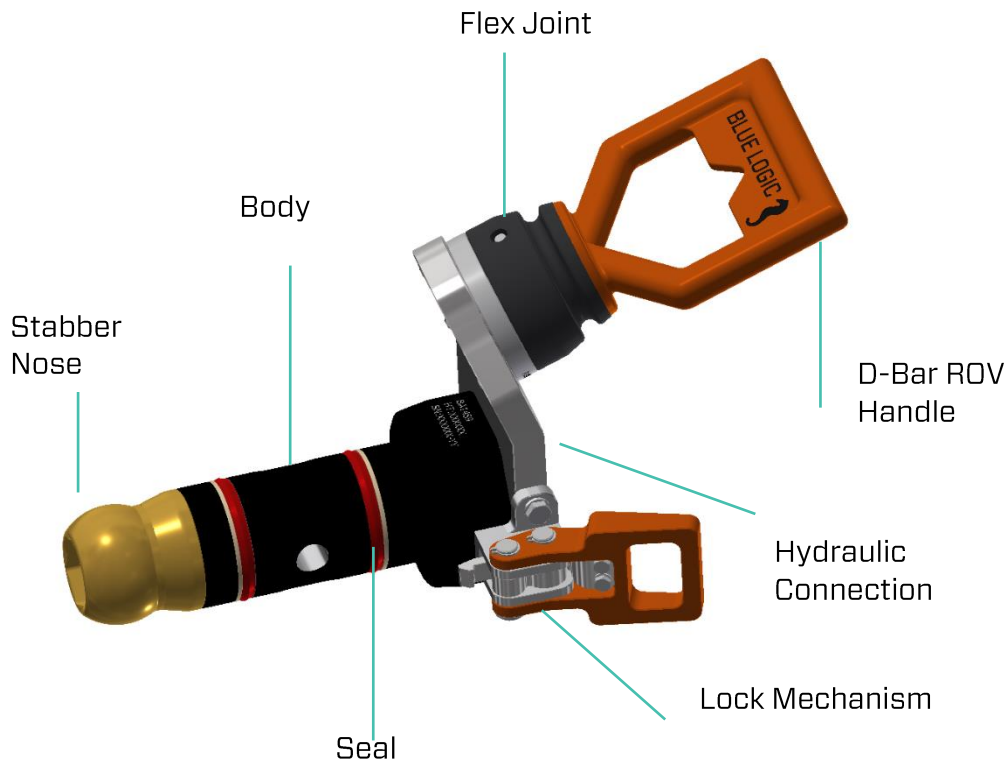

Figure 2 Typical Standard Ø55 Intervention Stab

2.4.1. Hydraulic Ports

The Ø55 Hot Stab System is delivered with different types of hydraulic connection, typically BSP, NPT or Autoclave. Please see product assembly drawing for further detailed information

## 2.5. RECEPTACLE

Receptacles are delivered in alternative materials with different hydraulic ports. See product assembly drawing for detailed information

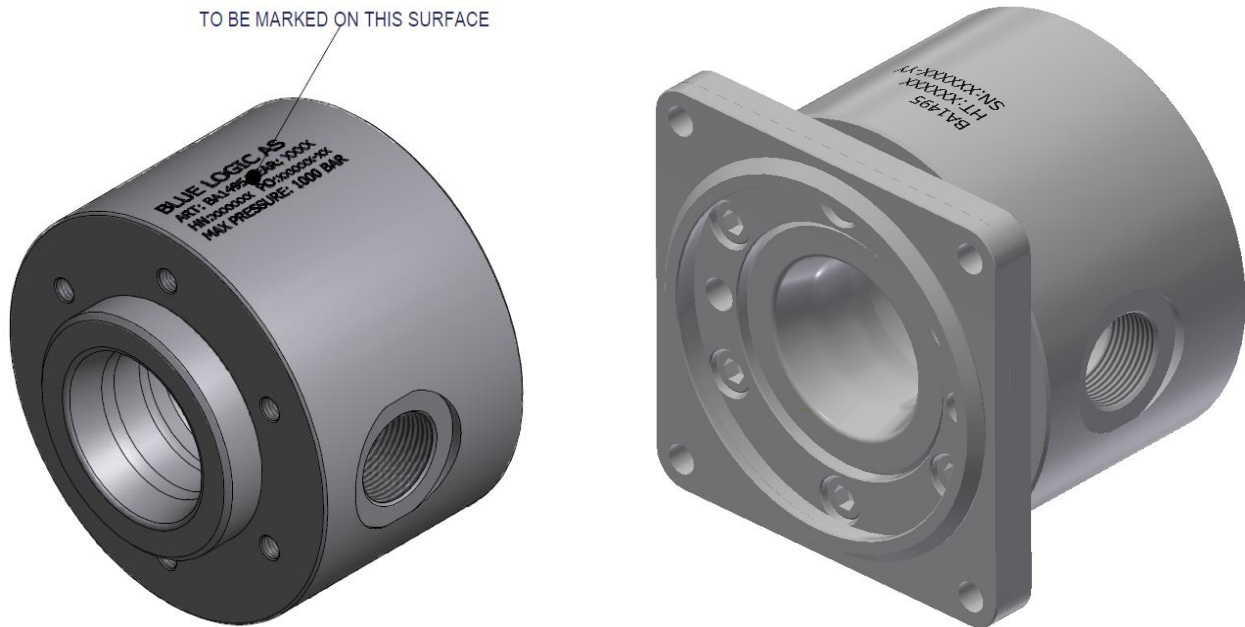

Figure 3 Typical Ø55 Single Port Receptacle with and without locking adapter plate

## 2.6. PROTECTION STAB

Protection stabs are delivered for permanent installation, both vented and non-vented versions.



Figure 4 Typical Ø55 Single Port Protection Stab

## 2.7. PRESSURE STAB

Pressure stabs can be delivered both for intervention and permanent installation.

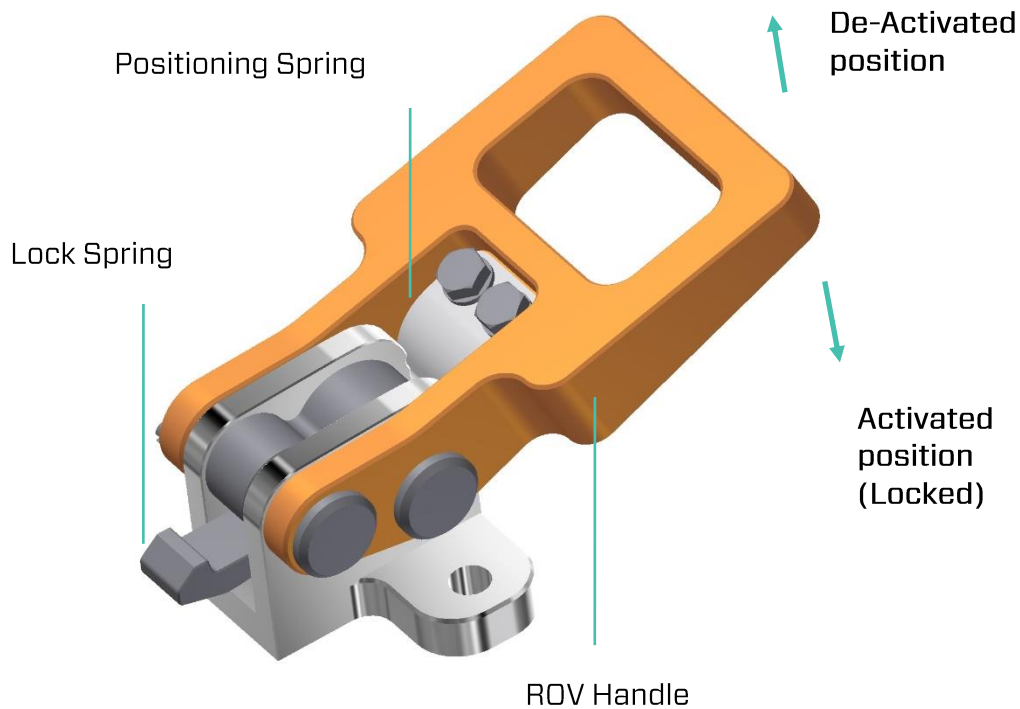

*Figure 5 Typical Ø55 Single Port Pressure Stab*

## 2.8. LOCKING MECHANISM

As an option, all Blue Logic Ø55 Hot Stab equipment can be delivered with ROV Operated locking mechanism thus securing the hot stab into the receptacle. The locking mechanism are installed and bolted directly onto the stabber body and locks onto the above described receptacle interface adapter.





*Figure 6 Locking Mechanism*

The lock has two positions; Activated and de-activated;

**Activated:** When the lock is placed in "Activated position", the stab can be inserted directly into the receptacle and lock automatically when fully inserted. Holding force approx. 3kN

**De-activated:** Lift the handle out from the stabber body. The hot stab can be pulled out from the receptacle.

### 3. INSTALLATION

#### 3.1. RECEPTACLE

##### 3.1.1. Installation of Receptacle

Recommended installation of the  $\varnothing 55$  Receptacles is to be bolted onto the subsea structure by use of the pre-drilled and threaded mechanical interface. Below figure shows typical receptacle interface. This interface can however vary. Always verify the interface on the dedicated product drawing first.

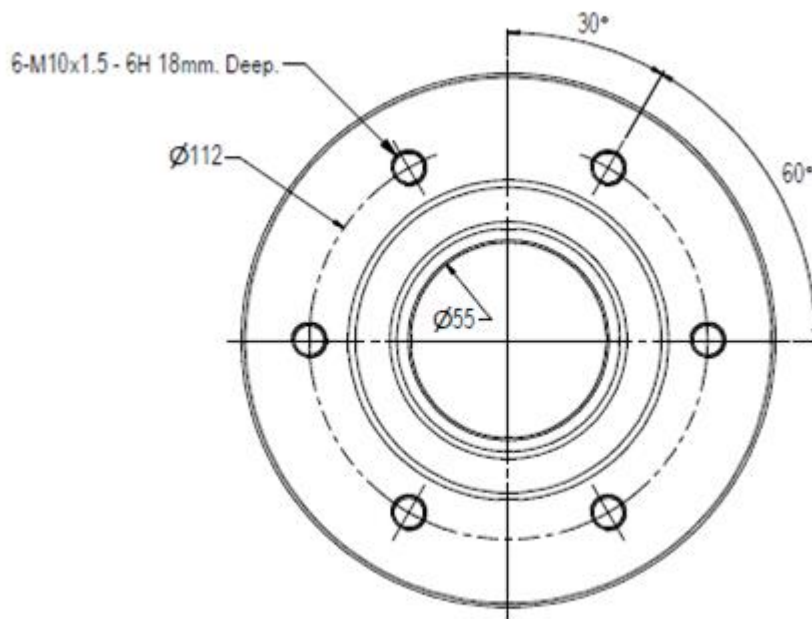

*Figure 7 Mechanical Interface Ø55 Receptacle*

Depending on material selection; electrical connection between the receptacles and panel should be verified as part of the installation. Serrated washers or dedicated earth cables should be considered.

Note that the receptacle design allows for stabber connection into receptacle from both sides.



## 4. OPERATION

### 4.1. PRE-DIVE CHECK

#### 4.1.1. Stab

No.	Description	Chk/Verified
01	Verify all fittings and hoses correct installed and secured	
02	Verify no leakages from hoses and connections	
03	Inspect all seals for damage. Replace if required	
04	Inspect Hot stab nose and body for mechanical damages and harmful scratches	
05	Inspect ROV handle for damages	
06	Inspect flex joint properly secured to stab body and ROV handle	
07	Verify functionality of flex joint. Ensure free to bend in all directions	
08	Inspect all hydraulic connectors, seals and valves	
09	Inspect all check valves for leakage (if relevant)	
10	Verify functionality of the locking system (Optional equipment)	

#### 4.1.2. Receptacle

No.	Description	Chk/Verified
01	Visual inspect receptacle internal surface finish and entrance area if possible.	
02	Ensure correct installation of the receptacle and free distance for hot stab guide nose behind rear receptacle opening	
03	Verify no leakages from hoses, piping and receptacle check valves.	
04	Verify ROV access and free space in front of receptacle and panel.	

## 4.2. CONNECTION

Both Stab's with and without locking system can be inserted directly into the receptacle without special preparations independent of axial rotation.

During insertion of the Hot Stab into the Receptacle there will be friction between Receptacle and stab seal system. Approximate stab force is 200N. This will however vary depending of temperature, lubrication etc.

#### 4.3. DISCONNECTION

Note; prior to disconnection, hydraulic pressure in the system should be bled off in order to reduce leakages to the environment. Since the Hot Stab system is a pressure balanced connection system, disconnection can be performed independently of system pressure.

Note; stab force will increase significantly if the system is pressurised.

#### 4.4. POST DIVE CHECK

No.	Description	Chk/Verified
01	Inspect all fittings and hoses for damages and loose connection	
02	Inspect all seals for damage. Replace if required	
03	Inspect Hot stab nose and body for mechanical damages and harmful scratches	
04	Inspect ROV handle for damages	
05	Inspect flex joint, verify functionality	
06	Clean all equipment and flush thoroughly with fresh water	
07	Dry the Hot Stab by use of pressurised air or by use of dry rags	
08	Apply preservation oil and secure in storage box.	

## 5. MAINTENANCE

### 5.1. SEAL REPLACEMENT

In standard configuration, the Blue Logic Hot Stab's are delivered with primary seal of HPU (PUR) material. These are of a special robust material and will handle numerous connections and mechanical wear and tear. This seal type has a clear red colour.

Alternative seal materials are available upon request when special requirements with regards to fluid compatibility are required.

#### 5.1.1. Removal of Seal

In order to remove old seals on the Hot Stab; cut gently by use of a knife or similar to split the seal. When cut, the seals can be easily removed by hand or by use of pliers.



Note; special attention should be made to avoid damages in the Stab seal area when using knives or other sharp objects.

#### 5.1.2. Installation of new Seal

Prior to installation, new seals should be heated in hot water to approx. 80-100°C. When the seals have been heated, they can be easily pulled into the stab and inserted into the seal groove.

There are available dedicated seal replacement tools for all Blue Logic Hot Stab Systems. Following sequence describes a typical seal replacement of using these dedicated tools.

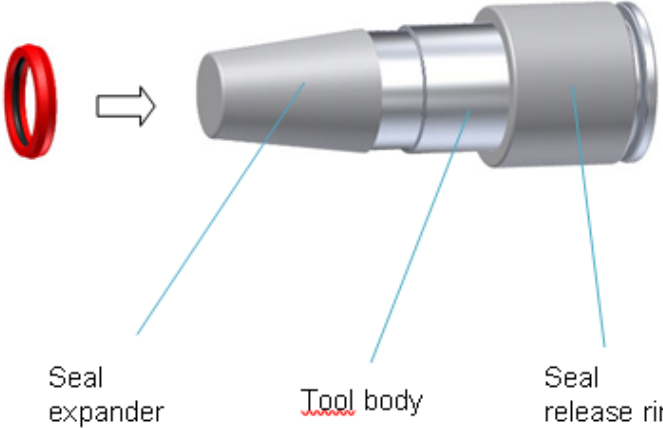
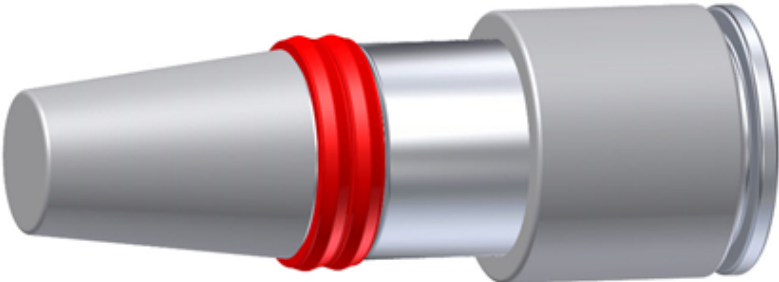
5.1.3. Installation of new Seal Using Seal Replacement Tool

 <p>Seal expander</p> <p>Tool body</p> <p>Seal release ring</p>	<p>Remove damaged seals from stab by use of knife or <u>nipper</u>.</p> <p>Preheat the seals in hot water (80-100°C)</p>
	<p>Push the seals onto the tool</p> <p>There is room for 2 seals at a time.</p>
	<p>Remove the seal expander in front of tool.</p>





	<p>Slide tool onto the stab until it reaches the slot furthest in.</p>
	<p>Push the seal release ring forward while holding back the tool, until the first seal are in place.</p>
	<p>Repeat at the second slot</p>
	<p>Reassemble the seal expander</p>

Figure 8 Seal replacement Storyboard

Note; if the Seal Replacement Tool is not available, heated seals can be pulled gently onto stab directly by hand if special attention is given.

## 5.2. ROV INTERFACE

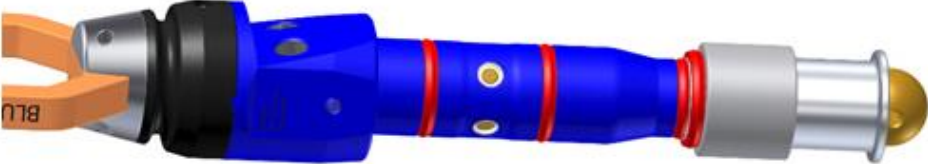
No special maintenance is required for the ROV handle/ ROV interface. Inspect for damages and replace if required.

## 5.3. FLEX JOINT

The flex joint can be removed and replaced by the following sequence:

1. Secure the Stab in a vice thus applying axial force between the Stab body and ROV Interface according to below figure
2. Unscrew the securing pin by use of a standard screwdriver
3. Remove the securing pin
4. Remove the Hot Stab from the vice
5. Remove the Flex element and ROV handle from Hot Stab body
6. Insert the new flex joint
7. Secure the Hot Stab in a vice and apply force between the Hot Stab body and ROV interface until the securing pin can be easily inserted by hand.
8. Rotate the securing pin by use of a screwdriver and secure by applying approx. 3Nm torque.
9. Remove the Hot Stab from the Vice
10. Inspect Hot Stab and verify functionality of flex joint.

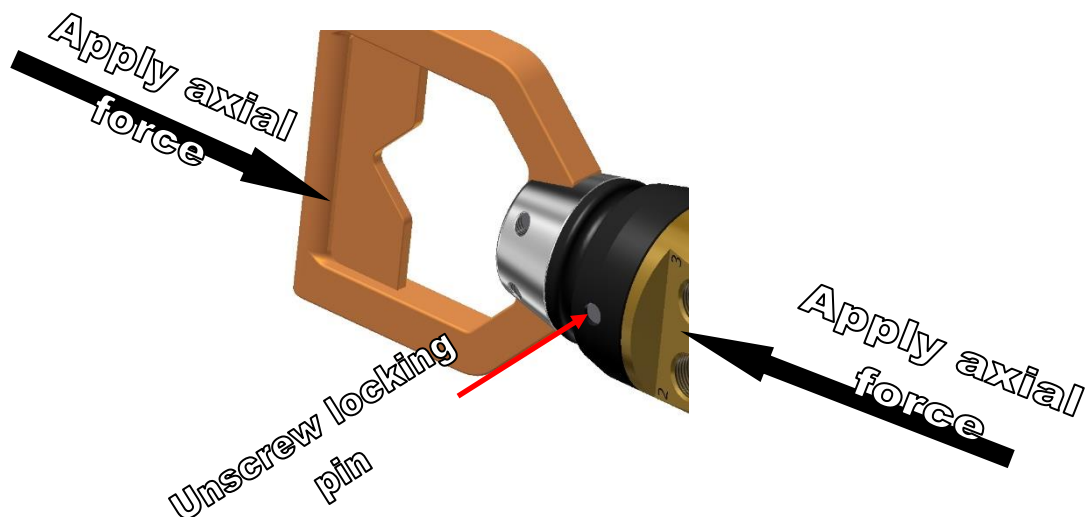

Figure 9 Flex joint installation

## 5.4. SPARE PARTS

For available spare parts, please visit: <http://e-sea.bluelogic.no/main.aspx>



## 6. STORAGE AND TRANSPORT

### 6.1. PRESERVATION FOR STORAGE

No.	Description	Chk/Verified
01	Visual inspect the Hot Stab for damages and wear.	
02	Ensure correct post dive sequence followed (see above sections)	
03	Apply preservation oil and secure in storage box.	

### 6.2. TRANSPORT

No special precautions are needed for transport. However, the following should be verified:

Correct packing; preferably by use of aluminium transport box

Verify the following

1. Sender Name and Address clearly visible
2. Receiver Name and address clearly visible
3. Inventory list correct filled out